

emporía

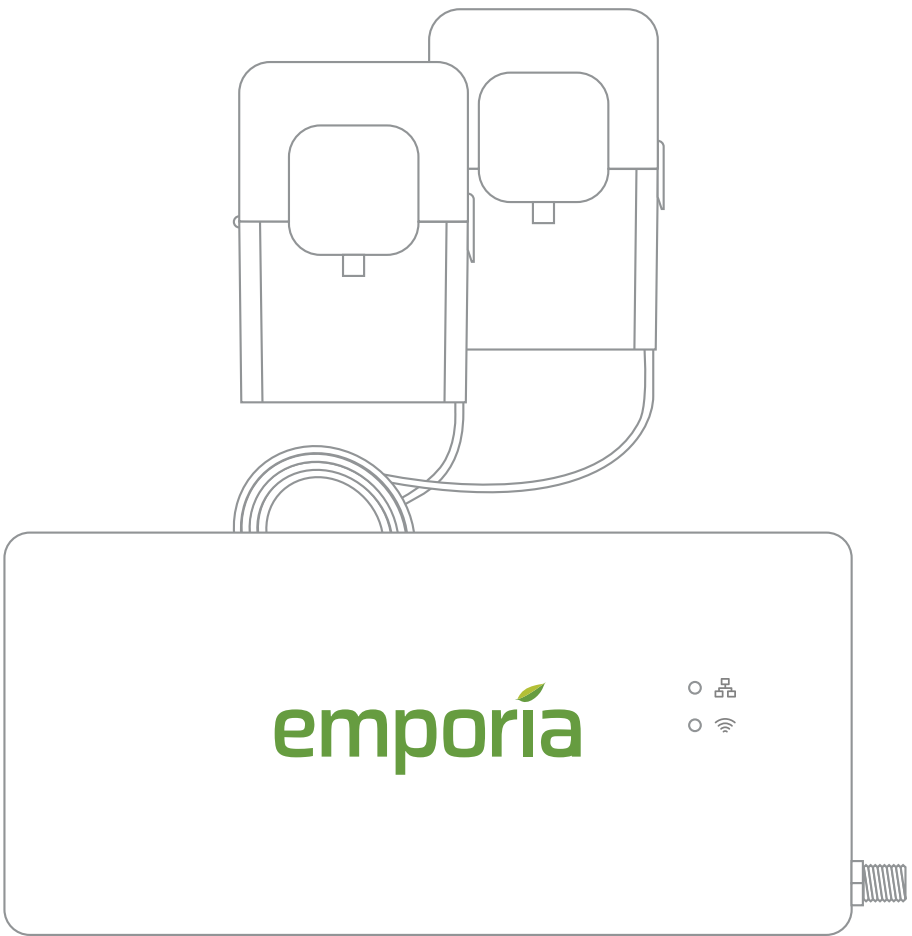

VUE

Smart Home
Energy Monitor
Gen 3

Installation Guide

Safety information



This is the safety alert symbol. It is used to alert you to potential personal injury hazards. Obey all safety messages that accompany this symbol to avoid possible injury or death.

WARNING

WARNING indicates a hazardous situation which, if not avoided, could result in death or serious injury.

WARNING

The Emporia Vue requires installing transformers inside a home's electrical panel and working around dangerous voltage that could lead to injury or death. The installation should be performed by a skilled person such as a licensed electrician or other qualified professional in accordance with the regional electrical code where it is being installed.

Improper installation or use of the equipment can be dangerous or even fatal. In no event shall Emporia be liable to you or any third party for any damages, either direct or indirect, arising from or related to any personal injury as a result of your failure to follow the safety information and instructions in this Installation Guide.

Need help?

emporiaenergy.com/support
support@emporiaenergy.com
1-844-EMPORIA (367-6742)

Safety information (continued)

WARNING

- Remove power from the electrical panel before inspecting. Wear protective eyewear and protective gloves before attempting to inspect the Vue system. Ensure no wiring for voltage measurement, current measurement, power, or data are frayed or have exposed conductors. Ensure there are no cracks, breaks, or other defects in the enclosure of the Vue or CTs.
- If you believe any of the Emporia Vue components may have been damaged, do not attempt to use them. Contact support at support@emporiaenergy.com immediately.
- Do not use the Emporia Vue in any manner other than specified in this installation guide, otherwise, the protection provided by the equipment may be impaired.
- Do not attempt to open, disassemble, or repair any of the components of the Emporia Vue.
- Do not install the Emporia Vue in environments with explosive gas or vapors; nor in damp or wet environments; nor in direct sunlight; nor where temperatures are consistently below -40°F (-40°C) or above 122°F (50°C).
- Ensure the Emporia Vue does not have power during any handling, including installation and disassembly.
- Do not perform any maintenance, service, or cleaning of the Vue after installation. Contact customer service for support.
- The Emporia Vue should only be used with Listed Energy-Monitoring Current Transformers.
- Basic Insulation, use CTs only on insulated conductor, secured from contacting live parts.
- To reduce risk of electric shock, always open or disconnect circuits from the power-distribution system (or service) of a building before installing or servicing current transformers.
- The Emporia Vue should be wired to power using 14AWG, 600V, UL1015, 105°C (or higher) copper-only wires
- It is recommended that the Emporia Vue be wired to the breaker closest to the device.
- Do not position the Emporia Vue so that it is difficult to operate disconnecting devices or breakers.
- Do not use 3rd party accessories or Current Transformers (CTs) with the Emporia Vue. The Vue and CTs are customized and integrated. Third party accessories or CTs may compromise the data accuracy and equipment safety.

Safety information (continued)

WARNING

- The current transformers may not be installed in equipment where they exceed 75 percent of the wiring space of any cross-sectional area within the equipment.
- Restrict installation of current transformers in an area where it would block ventilation openings.
- Restrict installation of current transformers in an area of breaker arc venting. Do not install the Emporia Vue Energy Monitor in any area where breaker arc venting exhaust gasses could be re-directed as a result of submetering equipment installation.
- The Emporia Vue is not suitable for Class 2 wiring methods and not intended for connection to Class 2 equipment. (Refer to NEC 2023, Section 725.)
- Secure current transformers and route conductors so that the conductors do not directly contact live terminals or buses.
- The Emporia Vue shall not be mounted within 50.8 mm (2 in) of any live parts including primary conductors, primary terminals, and primary lugs; but excluding insulated cables. It's acceptable for the Vue to be mounted to the grounded panel box and near the neutral/ground bus bars. The Vue employs Class I wiring allowing its wires to safely coexist with all other wires in the panel.
- If the Emporia Vue Energy Monitor is attached to the enclosure, it shall not contact the panel interior insulation such as the material that separates the GND and LIVE bus bars.
- Emporia Vue Energy Monitor mounting provisions shall not be attached to any energized part.
- Voltage sensing and power supply connections to the primary voltage shall have overcurrent protection through connection to a breaker/MCB.

Before you get started

The Emporia Vue is installed in a home's electrical panel. The main breaker will need to be set to the off position, which will shut off all of the power in the home. **However, the service mains will remain energized and dangerous.** The following may help with safe installation.

- Installation should be performed by a skilled person such as a licensed electrician or other qualified professional.
- Install in accordance with the regional electrical code where it is being installed.
- Ensure that the product specifications of the Vue are compatible with the system and the panel type where it is being installed.
- Identify the location of service disconnect. It may be outside of the panel.
- Ensure the work environment is clean with additional lighting available.
- Identify empty breakers or breakers that can be tapped for voltage monitoring. The number required corresponds to the system phases.
- The following items are recommended:



Insulated gloves

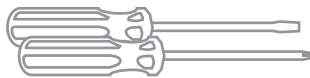

Phillips and flathead screwdrivers

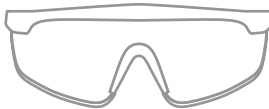

Protective eyewear



Alternative light source

What's in the box

The Emporia Vue contains the following items. **If any of these items are missing or if you believe they've been damaged, contact support immediately.**



Vue energy monitor



Two or three (depending on bundle) Main 200A current transformers (CTs) with 22 AWG wire and 5mm screw terminal plugs



0, 8, or 16 (depending on bundle) Branch 50A current transformers (CTs) with 22 AWG wire and 3.8mm screw terminal plugs



Wire harness with 7.6mm screw terminal plugs and 4x14AWG wire leads

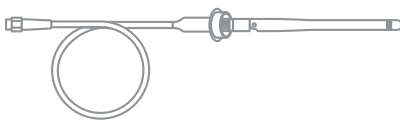

WiFi antenna assembly

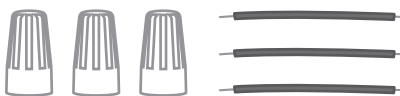

Two or three (depending on bundle) wire nuts and three 14 AWG, 600V splicing wires

Need help?

emporiaenergy.com/support
support@emporiaenergy.com
1-844-EMPORIA (367-6742)

Energy monitor connections

The energy monitor is the hub of the Emporia Vue. The screw terminal port for the wiring harness is located on the left-hand side of the monitor. The screw terminal ports across the top of the monitor are the inputs for the 50A Branch Current Transformers (CTs) (the bundle may have come with 8 or 16 CTs, or none at all).

The A, B, and C screw terminal ports on the right side of the monitor are the inputs for the 200A Main CTs (the bundle may have shipped with two or three). The RJ45 LAN port and coaxial connector for the WiFi antenna cable are also on the right hand side of the monitor. All of the ports are clearly labeled on the energy monitor.

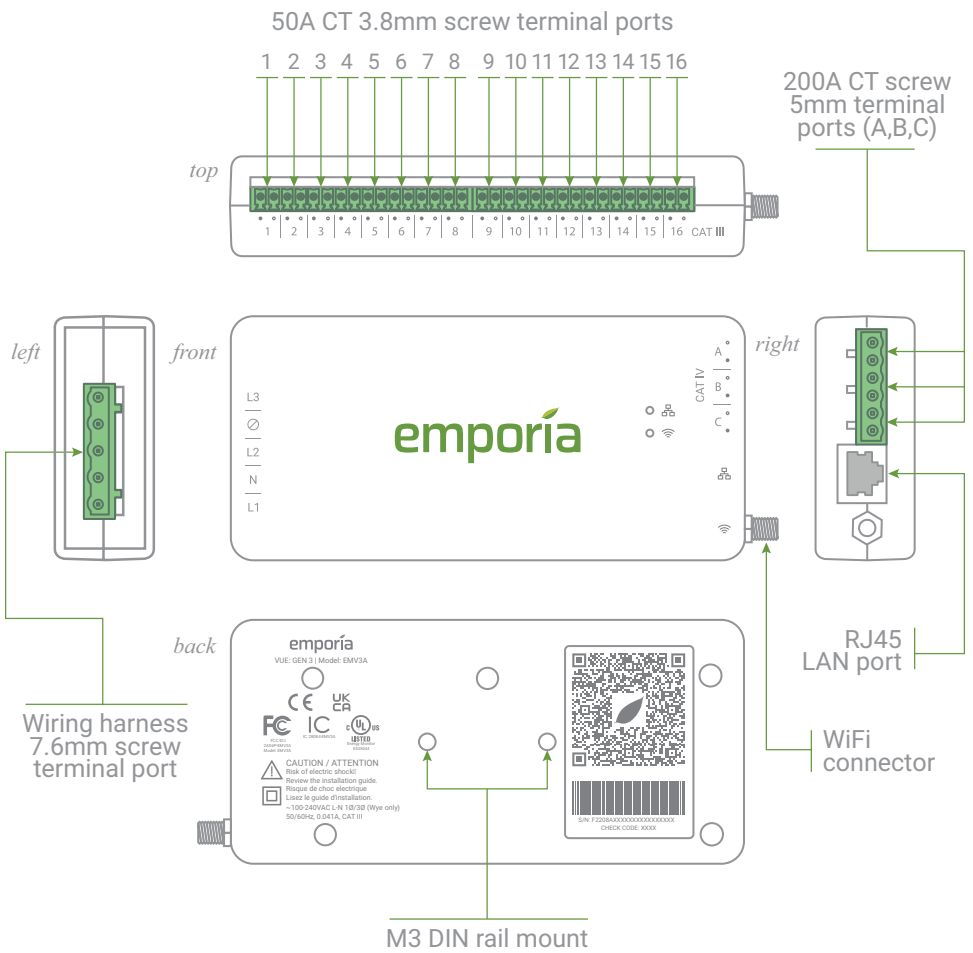

Step 1: Download the app

Use the camera on your phone to scan the unique QR code located either on the **back of the Vue** energy monitor or on the **Getting Started Guide** included in the box. This QR code will both download the **Emporia Energy app** onto a phone or tablet from the Apple App Store or Google Play and start the Vue setup process. Once the app is downloaded, you'll be prompted to **create an account** if you don't have one.

Also, if you plan to connect the Vue to the internet via Wi-Fi, this is a great time to use a phone to check the signal strength of the Wi-Fi network next to the electrical panel in the home. Low/no signal may require a Wi-Fi extender or an ethernet connection for the Vue to work properly.

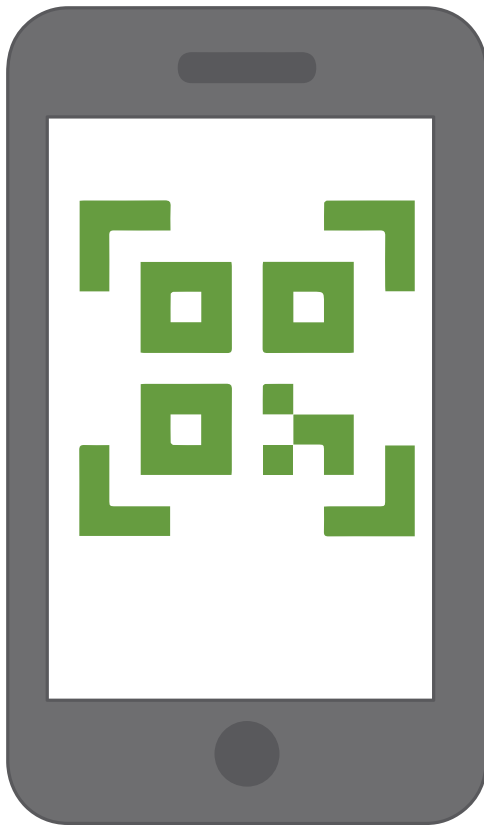

Step 2: Turn off the main breaker and remove the cover

First, turn service disconnects and/or main breakers feeding the panel into the OFF position. Note that these may be located outside of the panel in which you're installing the Vue. Next, remove any screws holding the cover to the panel and remove the cover to access the circuit breakers and **the energized service mains!**



Service disconnect may be located outside of the panel

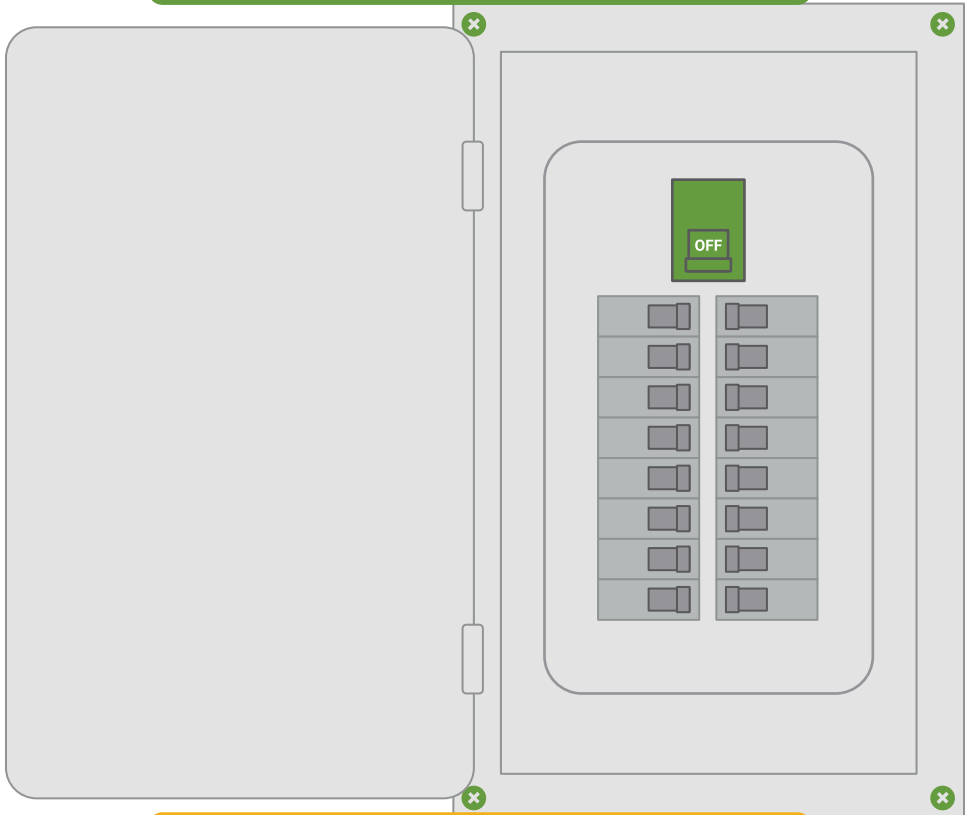

DANGER: The service mains are energized!

Need help?

emporiaenergy.com/support
support@emporiaenergy.com
1-844-EMPORIA (367-6742)

Step 3: Find a place for the monitor

Locate a place within the electrical panel for the Vue energy monitor **ensuring it is at least 50.8mm (2 in) from any live parts** including primary conductors, primary terminals, and primary lugs; but excluding insulated cables. The breaker box may be oriented differently than below, but the monitor is small and designed to fit easily in the box. Find a place that works. If the Vue is to be mounted on a DIN rail, the monitor has two threaded screw holes to attach mounting hardware using two M3 screws and lock washers (sold separately).

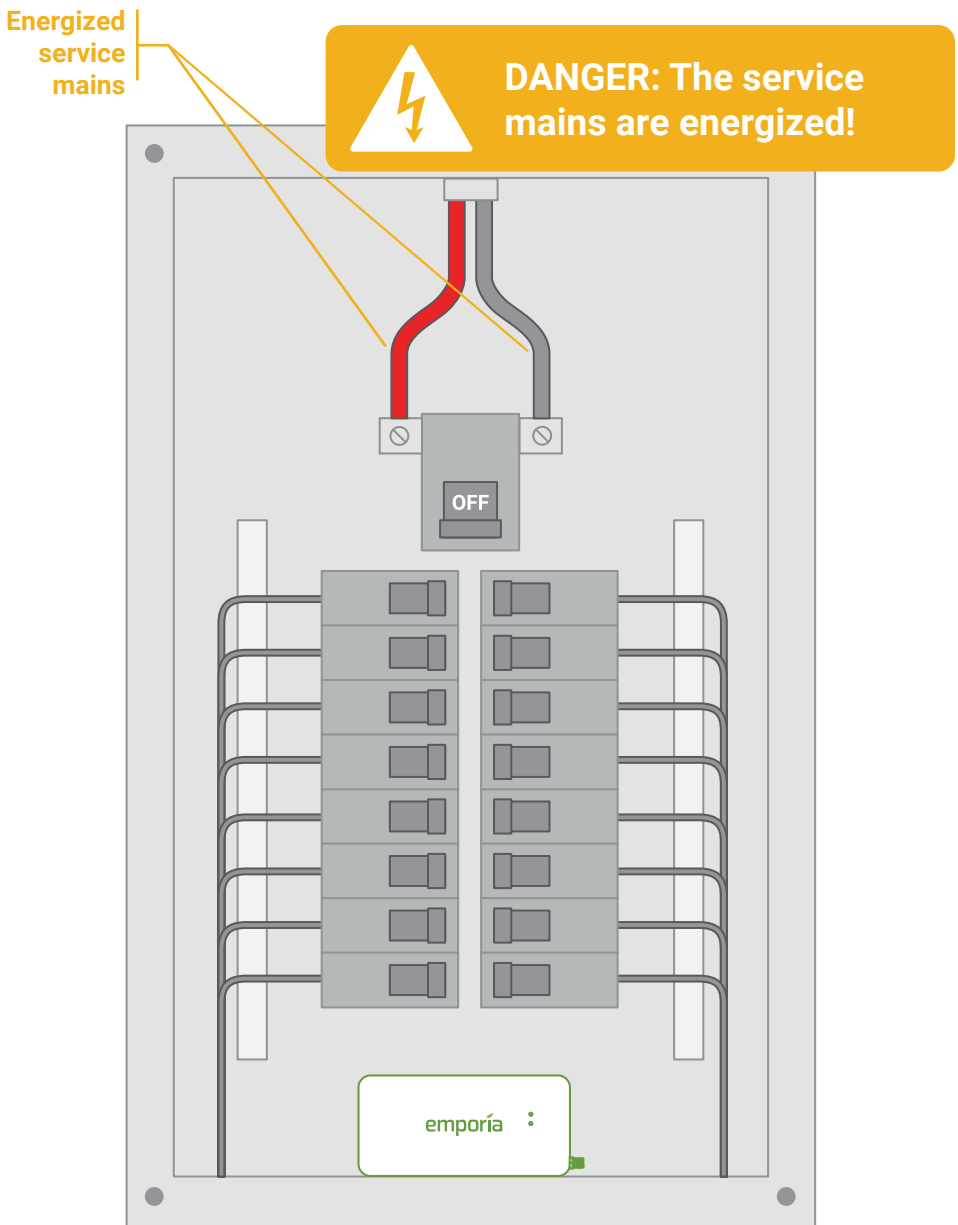

Step 4: Prepare for internet connection

The Vue is capable of connecting to the internet either via a wired LAN connection, a Wi-Fi connection, **or both**. If both are implemented, the Vue will prioritize wired LAN. If a wired LAN is unavailable, the Vue will attempt to connect over Wi-Fi. Choose the preferred method(s) and go to the corresponding step below.



Need help?

emporიაenergy.com/support
support@emporიაenergy.com
1-844-EMPORIA (367-6742)

Step 4(a): Prepare for wired LAN connection

This step is to prepare for a wired internet connection. To connect to the internet wirelessly via Wi-Fi, see Step 4(b). Run a Cat5e or higher ethernet cable with an RJ45 connector from a router, switch, or modem to the electrical panel. Then, use a screwdriver to remove a knockout from the electrical panel. Next, feed the cable through the hole to the Vue and plug it in the socket on the right-hand side of the energy monitor marked .

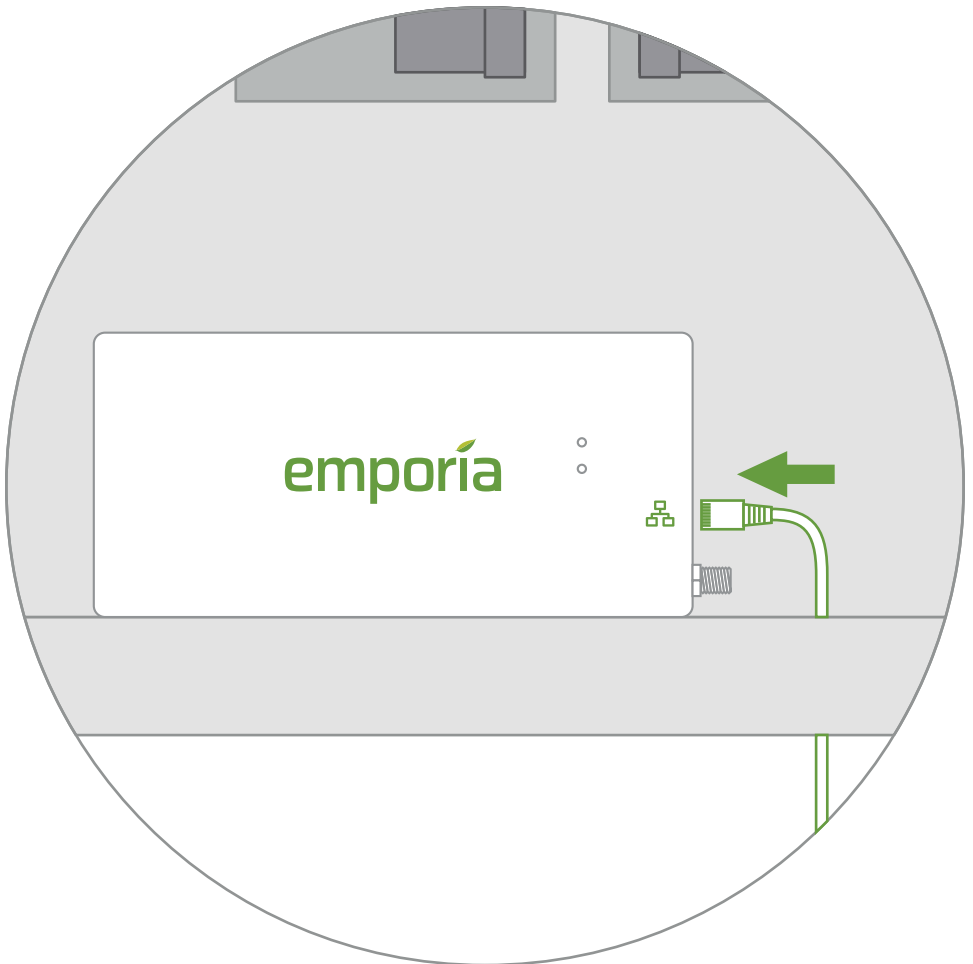

Need help?

emporiaenergy.com/support
support@emporiaenergy.com
1-844-EMPORIA (367-6742)

Step 4(b): Prepare for Wi-Fi connection

This step is to prepare for a wireless internet connection. To connect to the internet via wired LAN, see Step 4(a). Use a screwdriver to remove a knockout from the electrical panel. Now, feed the antenna through the hole. Then, screw the antenna assembly cable to the right-hand side of the energy monitor in the coaxial connector marked . Finally, plug the hole with the knockout plug. It's acceptable to install the antenna inside of a wall.

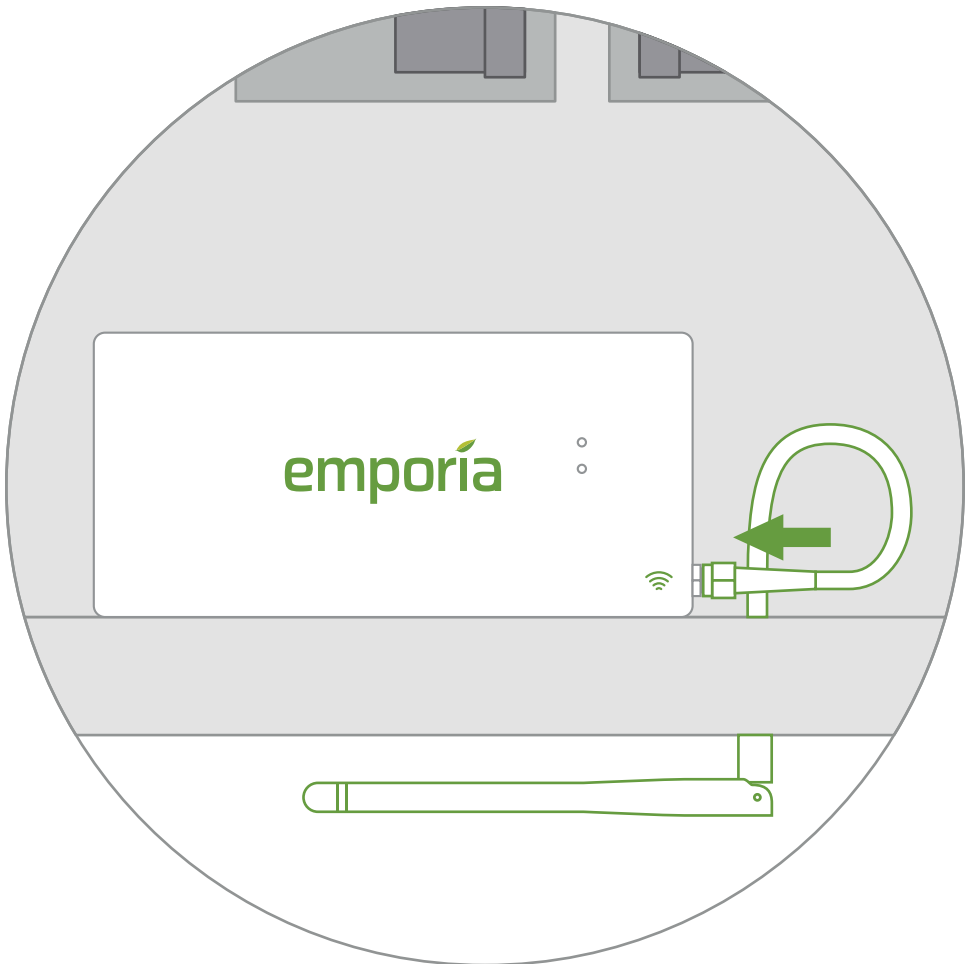

Need help?

emporiaenergy.com/support
support@emporiaenergy.com
1-844-EMPORIA (367-6742)

Step 5: Installing the Main current transformers

The Main CTs will attach to the incoming live mains. **They should not be used on neutral lines.** They will be installed differently depending upon whether or not the home has solar and how that solar system is connected to the electrical system. The Vue will be installed differently depending on whether the solar is a breaker-fed or a line-side tap installation. The Main CTs that connect to the mains will provide net metering out of the box – displaying electricity used minus electricity produced. These installations are covered in the subsequent pages. To monitor electricity used and electricity produced separately, Branch CTs will be used as described in **Step 8**.

- **Step 5(a): No solar Main CT**
- **Step 5(b): Breaker-fed solar Main CT**
- **Step 5(c): Line-side tap solar Main CT**

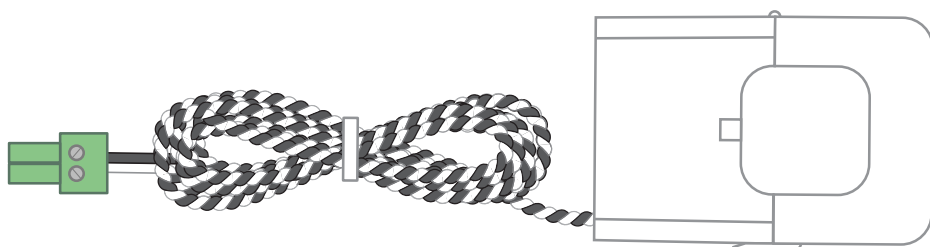

Need help?

emporiaenergy.com/support
support@emporiaenergy.com
1-844-EMPORIA (367-6742)

Step 5(a): No solar Main CT installation

Open the clasps on the CTs and place each clamp around one of the main service cables. Then, shut the clasps to secure the CTs. **IMPORTANT! The Breaker imprint on the bottom of the CTs should point toward the breakers.** Finally, insert the screw terminal plugs into the ports on the right side of the monitor. To avoid clutter, unscrew the 22 AWG wires from the screw terminals, cut them to size, and reattach them ensuring the black and white wires match the icons on the front of the Vue.

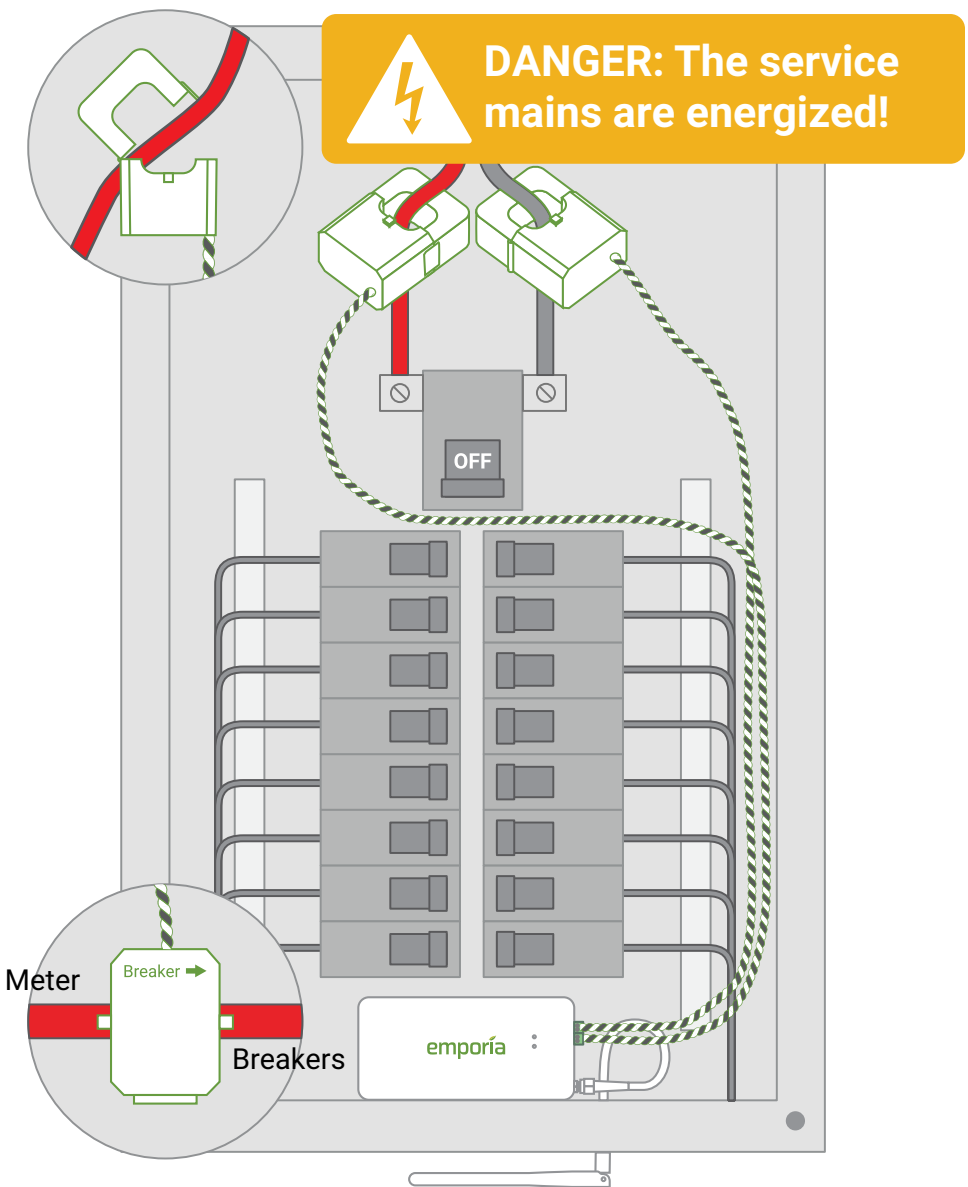

Need help?

emporiaenergy.com/support
support@emporiaenergy.com
1-844-EMPORIA (367-6742)

Step 5(c): Line-side tap solar Main CT installation

Open the clasps on the CTs and place each clamp around one of the main service cables between the utility meter and incoming line-side inverter taps. Then, shut the clasps to secure the CTs. **IMPORTANT! The Breaker imprint on the bottom of the CTs should point toward the breakers.** Finally, insert the screw terminal plugs into the ports on the right side of the monitor. To avoid clutter, unscrew the 22 AWG wires from the screw terminals, cut them to size, and reattach them ensuring the black and white wires match the icons on the front of the Vue.

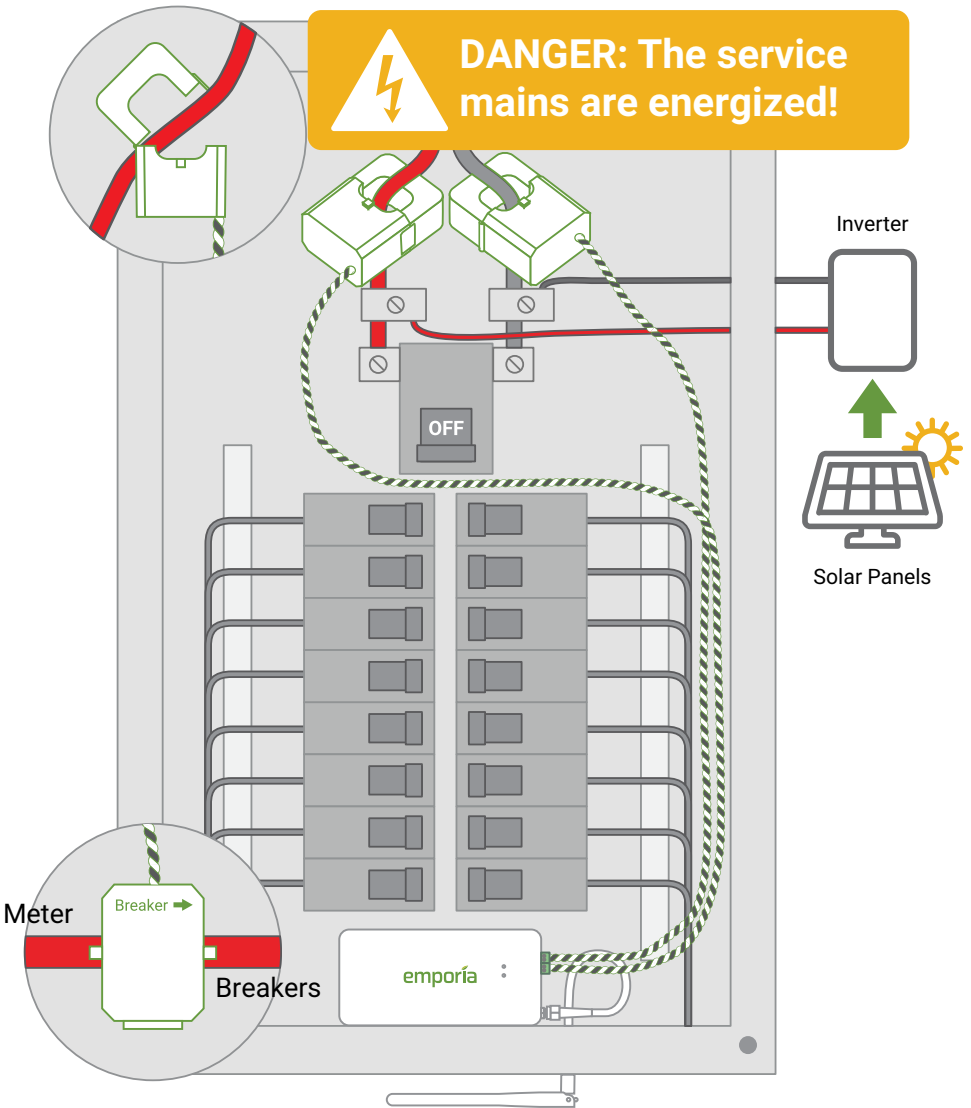

Need help?

emporiaenergy.com/support
support@emporiaenergy.com
1-844-EMPORIA (367-6742)

Step 6: Plug in the voltage sensing wire harness

Insert the 7.6mm screw terminal plug of the power supply wiring harness with four 16 AWG wire leads into the port of the left side of the energy monitor until it clicks into place securely. These wires can also be cut to length to reduce panel clutter. The wire harness allows for single-phase power and three-phase voltage sensing: **Black (L1)** provides power and voltage sensing, **White (N)** connects to Neutral, and **Red (L2)** and **Blue (L3)** provide voltage sensing only (if applicable).

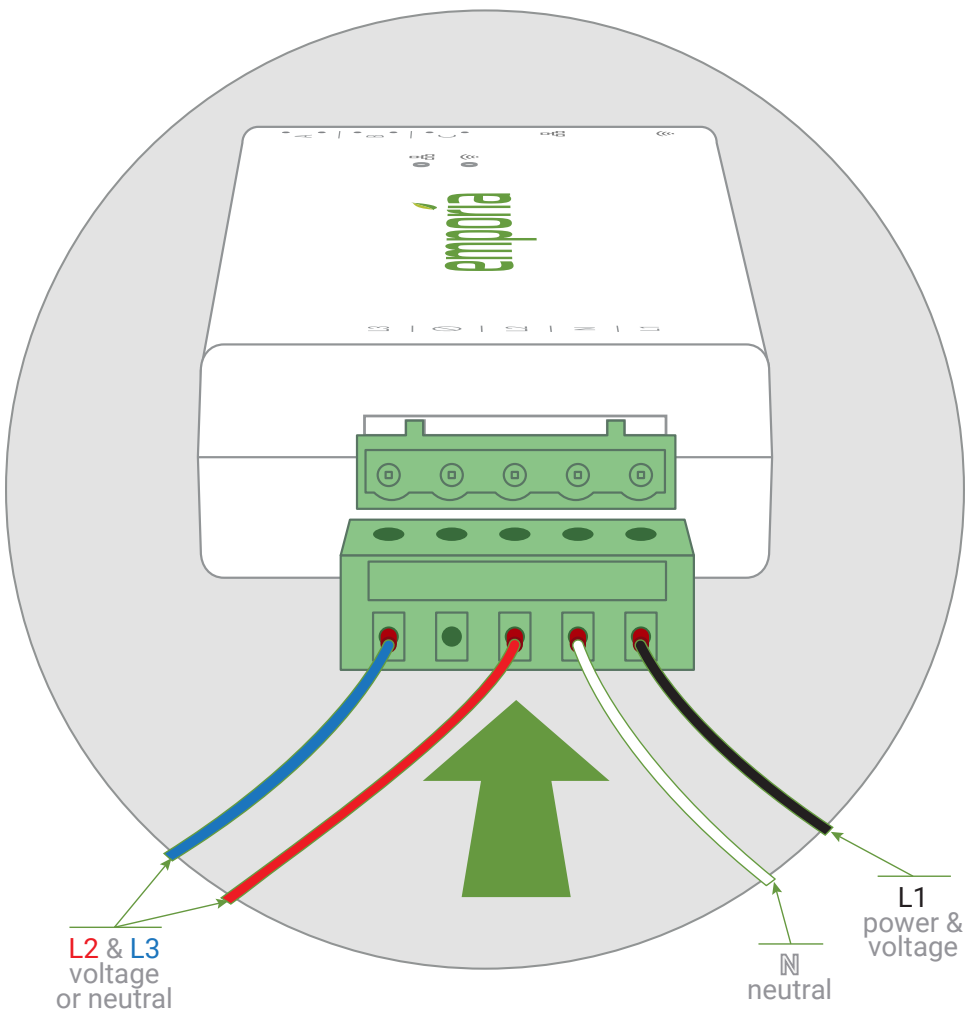

Need help?

emporiaenergy.com/support
support@emporiaenergy.com
1-844-EMPORIA (367-6742)

Step 7: Connect the wire harness

For North American Homes

The wire harness is wired to one or more breakers in the electric panel.

1.) Wiring to an empty breaker

If wiring to an empty (unused) breaker, wire it directly to the breaker. Ampacity rating of this breaker does not matter.

2.) Wiring to an in-use breaker

If wiring to an in-use breaker, use the splicing wires / wire nuts included with the Vue for breakers rated up to 15A. Any ampacity rating may be used if the splicing wire gauge matches the existing wire and meets applicable electric codes.

3.) Only if wiring to a AFCI / GFCI breaker

If the wire harness is wired to an AFCI / GFCI breaker, **the black wire needs to be wired to the hot side and the white to the neutral on this breaker. The white is not wired to the neutral bus. The red wire will need to be wired to the hot side of the breaker above or below the AFCI / GFCI breaker.**

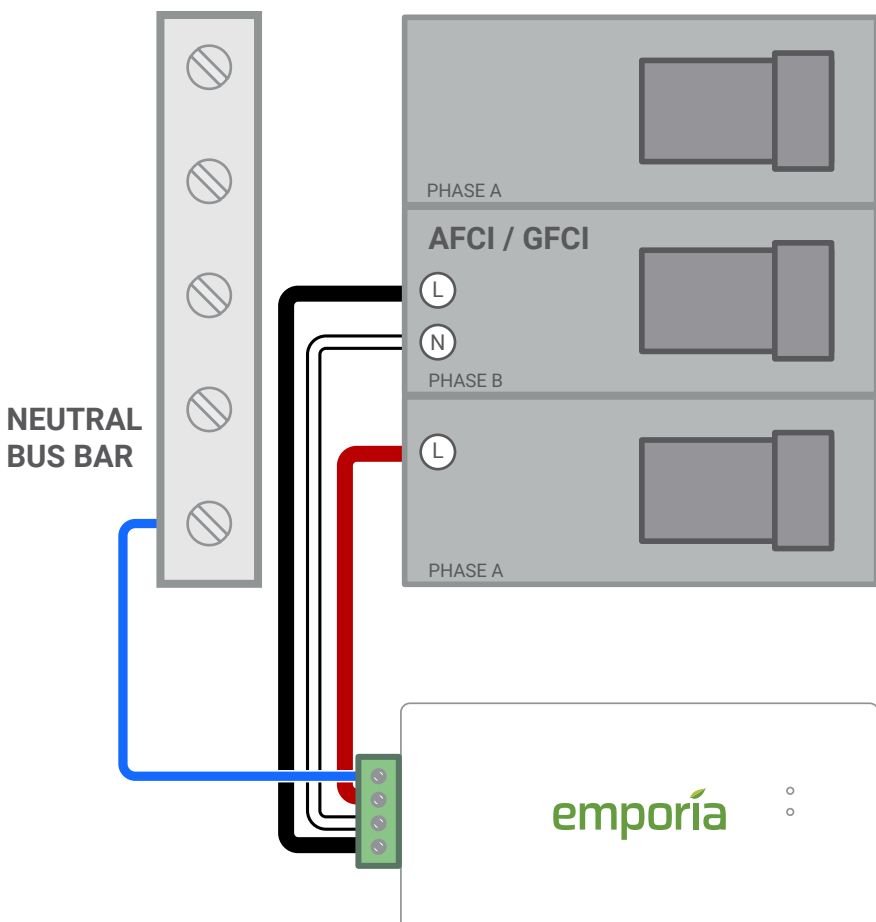

Step 7 (continued): Connect the wire harness

The voltage sensing wire harness will be connected differently depending on the number of Main CTs installed in Step 5 as well as whether or not there are an adequate number of empty breakers. Go to the step below based on the system. If you're unsure, contact Emporia Support and we'll help you through it.

Step 7(a) Common in N. American homes

- Two empty breakers
- Two Main CTs

Step 7(b) Common in N. American homes

- No empty breaker
- Two Main CTs

Step 7(a): Two empty breakers and two Main CTs

Secure the **White (N)** and **Blue (L3)** wires from the wire harness to the neutral bus bar. Turn off two vertically adjacent (stacked) single pole breakers and secure the **Black (L1)** and **Red (L2)** wires from the harness to each of the hot leads from each breaker.

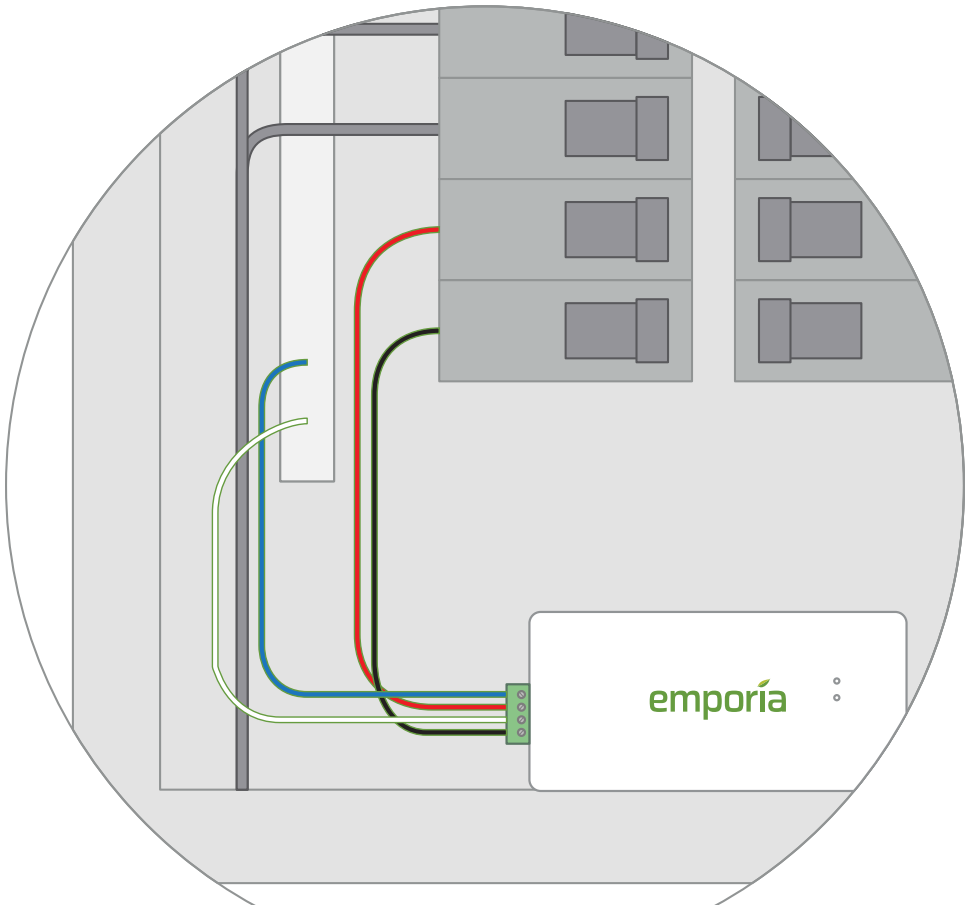

Any empty breaker size can be used in this scenario (not limited to 15A)

Need help?

emporiaenergy.com/support
support@emporiaenergy.com
1-844-EMPORIA (367-6742)

Step 7(b): No empty breaker and two Main CTs

Secure the **White (N)** and **Blue (L3)** wires from the wire harness to the neutral bus bar. Turn off two vertically adjacent (stacked) 15A single pole breakers and remove their wires. Connect one of the breaker wires to the **Black (L1)** harness wire and a splicing wire with a wire nut. Next, connect the second breaker wire to the **Red (L2)** harness wire and a splicing wire with a wire nut. Then secure each of the extra wires to the two breaker poles.

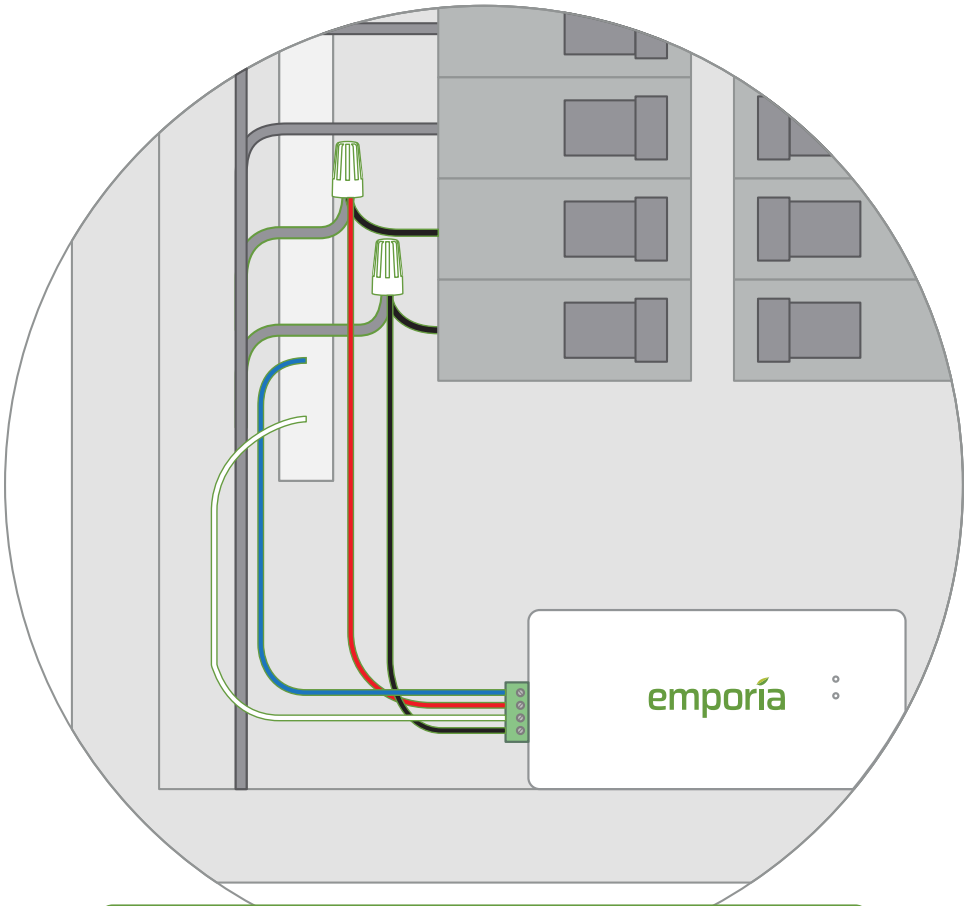

A larger amp breaker may be used if the gauge of the splicing wire matches the existing gauge wire from the breaker meeting the national and regional codes

Need help?

emporiaenergy.com/support
support@emporiaenergy.com
1-844-EMPORIA (367-6742)

Step 8: Connect the wire harness

For North American Commercial Systems and European Homes

Step 8(a) Common in European 3-phase homes
Common in N. American Commercial systems

- Three empty breakers
- Three Main CTs

Step 8(b) Common in European 3-phase homes
Common in N. American Commercial systems

- No empty breaker
- Three Main CTs

Step 8(c) Common in European 1-phase homes

- One empty breaker
- One Main CT

Step 8(d) Common in European 1-phase homes

- No empty breaker
- One Main CT

Step 8(a): Three empty breakers and three Main CTs

Secure the **White (N)** wire from the wire harness to the neutral bus bar. Turn off three vertically adjacent (stacked) single pole breakers and secure the **Black (L1)**, **Red (L2)**, and **Blue (L3)** wires from the harness to each of the hot leads from each breaker.

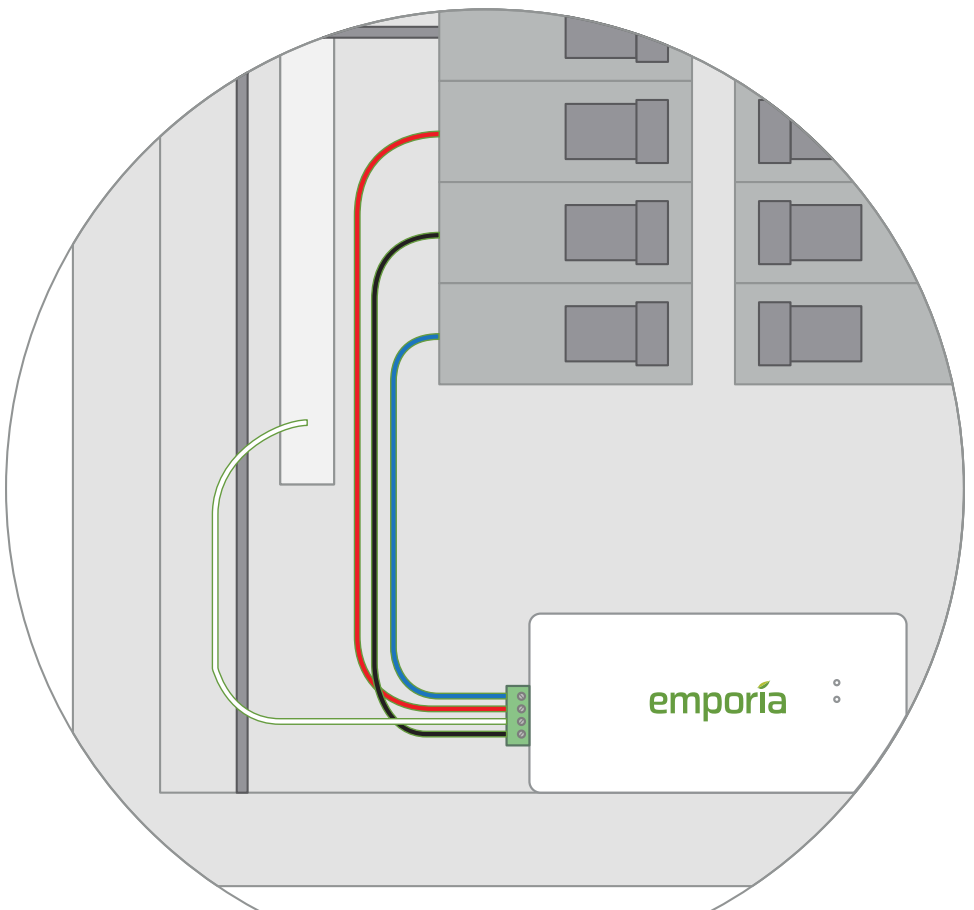

Any empty breaker size can be used in this scenario (not limited to 15A)

Need help?

emporiaenergy.com/support
support@emporiaenergy.com
1-844-EMPORIA (367-6742)

Step 8(b): No empty breaker and three Main CTs

Secure the **White (N)** wire from the wire harness to the neutral bus bar. Turn off three vertically adjacent (stacked) 15A single pole breakers and remove their wires. Connect one of the breaker wires to the **Black (L1)** harness wire and a splicing wire with a wire nut. Next, connect the second breaker wire to the **Red (L2)** harness wire and a splicing wire with a wire nut. Next, connect the third breaker wire to the **Blue (L3)** harness wire and a splicing wire with a wire nut. Then secure each of the splicing wires to the three breaker poles.

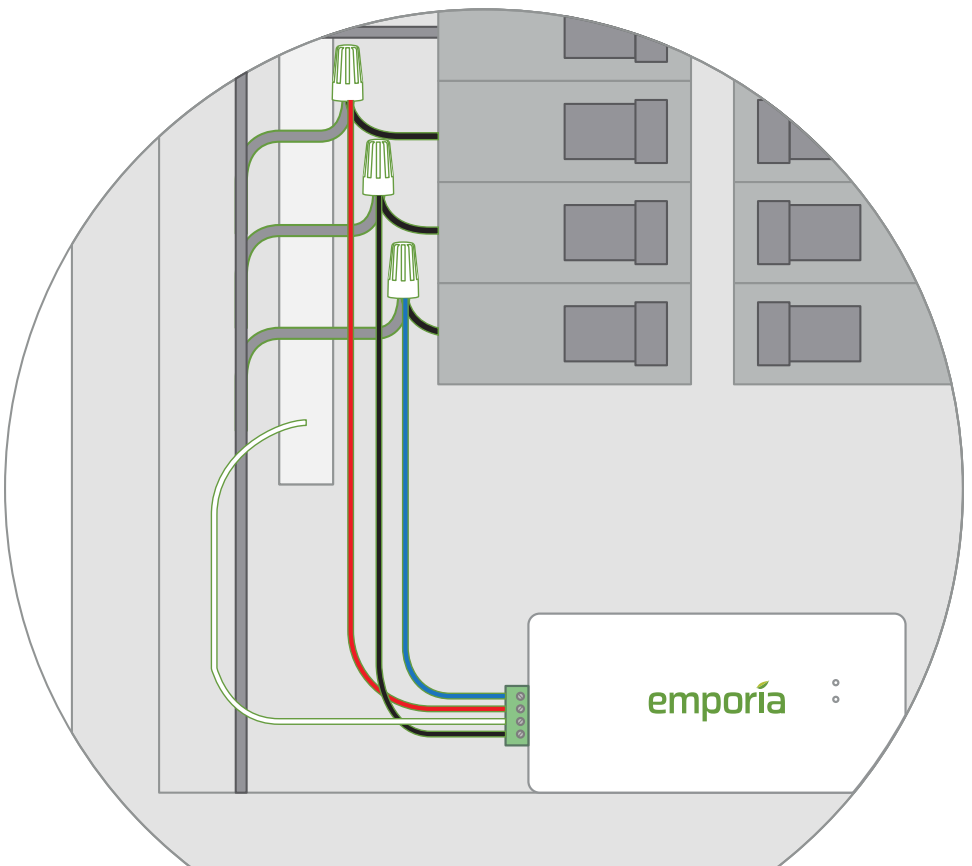

A larger amp breaker may be used if the gauge of the splicing wire matches the existing gauge wire from the breaker meeting the national and regional codes

Need help?

emporiaenergy.com/support
support@emporiaenergy.com
1-844-EMPORIA (367-6742)

Step 8(c): One empty breaker and one Main CT

Secure the **White (N)**, **Red (L2)**, and **Blue (L3)** wires from the wiring harness to the neutral block (you can use a wire nut and splicing wire if needed). Turn off an empty MCB and secure the **Black (L1)** wire from the harness to the hot lead from the MCB.

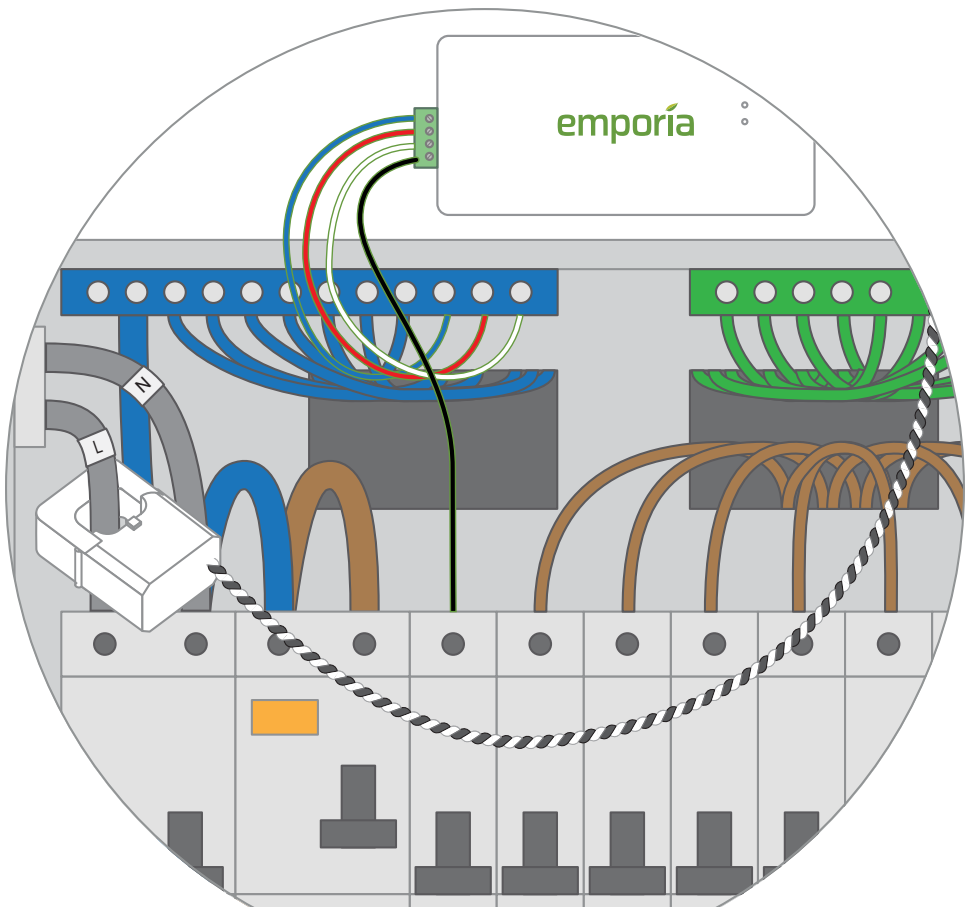

Any empty MCB size can be used in this scenario (not limited to 15A)

Need help?

emporიაenergy.com/support
support@emporიაenergy.com
1-844-EMPORIA (367-6742)

Step 8(d): No empty breaker and one Main CT

Secure the **White (N)**, **Red (L2)**, and **Blue (L3)** wires from the wire harness to the neutral block. Turn off a 15A MCB and disconnect its wire. Connect that wire to the **Black (L1)** wire from the harness and a splicing wire with the wire nut. Then secure the splicing Wire to the MCB.

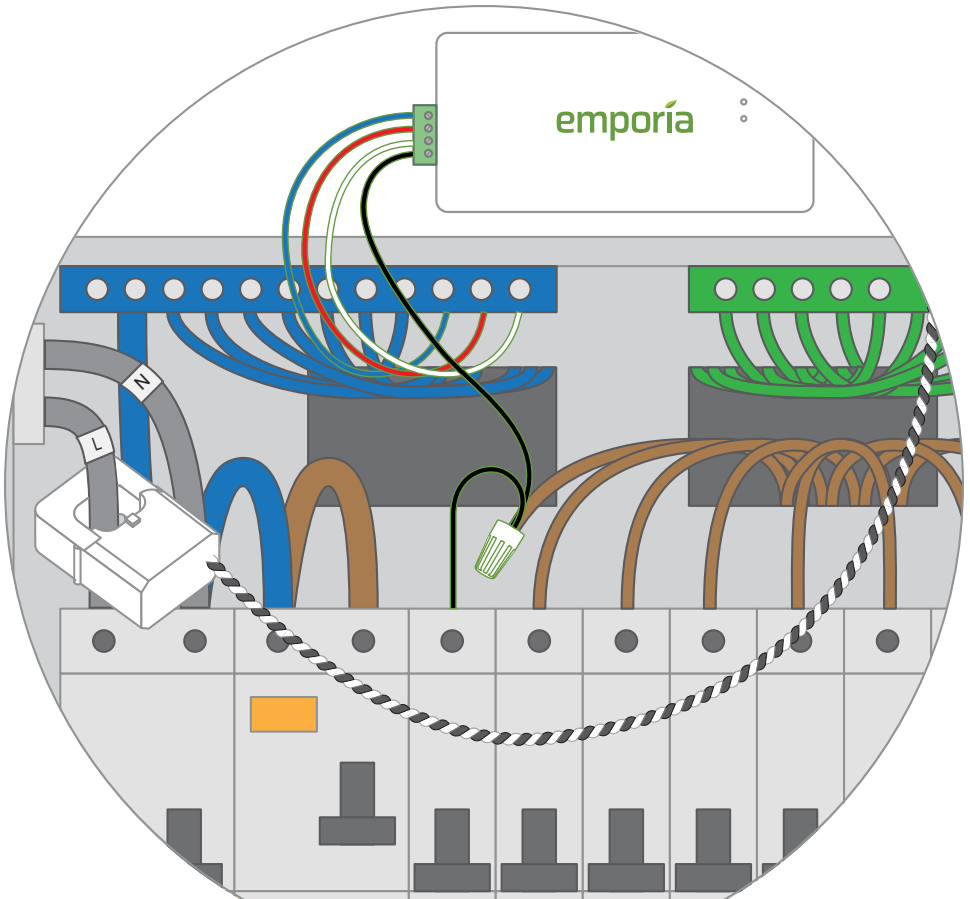

A larger amp breaker may be used if the gauge of the splicing wire matches the existing gauge wire from the breaker meeting the national and regional codes

Need help?

emporíaenergy.com/support
support@emporíaenergy.com
1-844-EMPORIA (367-6742)

Step 9: Plug in and connect the Branch current transformers

If the Vue has Branch CTs, open the clasps on the CTs and place each clamp around the non-neutral leg from the breaker that is to be monitored. Then shut the clasps to secure the CTs. Then, insert the screw terminal plugs into the ports on the top of the energy monitor. Note the port numbers. To avoid clutter, unscrew the 22 AWG wires from the screw terminals, cut them to size, and reattach them ensuring the black and white wires match the icons on the top of the Vue.

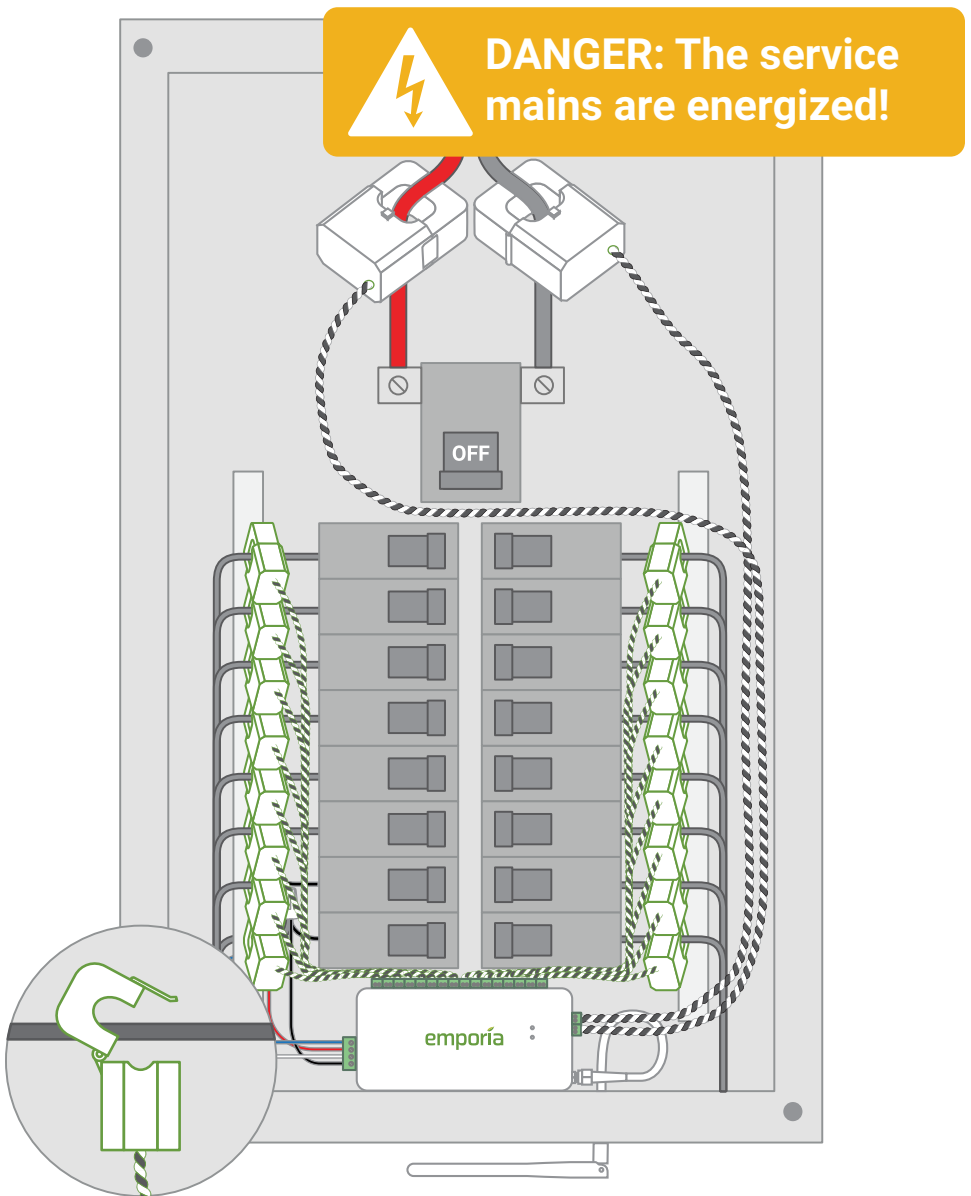

Need help?

emporiaenergy.com/support
support@emporiaenergy.com
1-844-EMPORIA (367-6742)

Step 9 (continued): A note about multi-pole breakers

If 2- or 3-pole breakers are to be monitored, we recommended that one CT be used for on each pole; however, to conserve the number of CTs, a single CT can be used. To use a single CT, clasp the clamp around either one of the non-neutral leads coming off the breaker (it doesn't matter which). When only one CT is used, input a circuit multiplier in the app to double or triple the reading by entering a "2" or "1.7". **Using a single CT to monitor a multi-pole breaker does not accurately monitor unbalanced loads.**

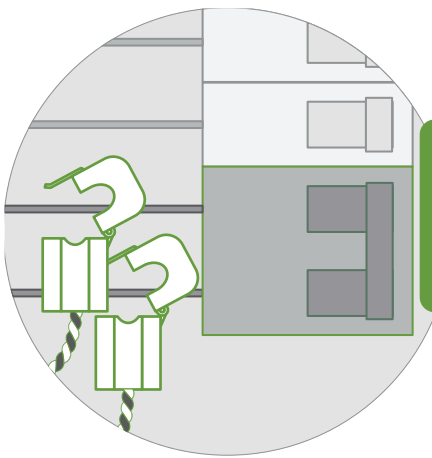

Most accurate - Attach one branch sensor on each leg of the breaker

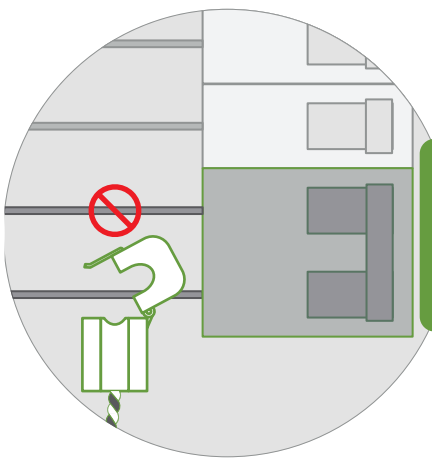

Less accurate - Attach one branch sensor on a single leg and use an app multiplier.

Need help?

emporiaenergy.com/support
support@emporiaenergy.com
1-844-EMPORIA (367-6742)

Step 9 (continued): A note about solar monitoring

For the Vue to be able to calculate how much energy from the system is going to and from the grid, Branch CTs will need to be connected to the incoming leads from the inverter regardless of whether the solar is a **breaker-fed** or a **line-side tap** installation. **Specify the circuits monitored by these CTs as 'Solar/Generation' in the app.** If only one CT is used, input a circuit multiplier in the app to double or triple the reading by entering a "2" or "1.7".

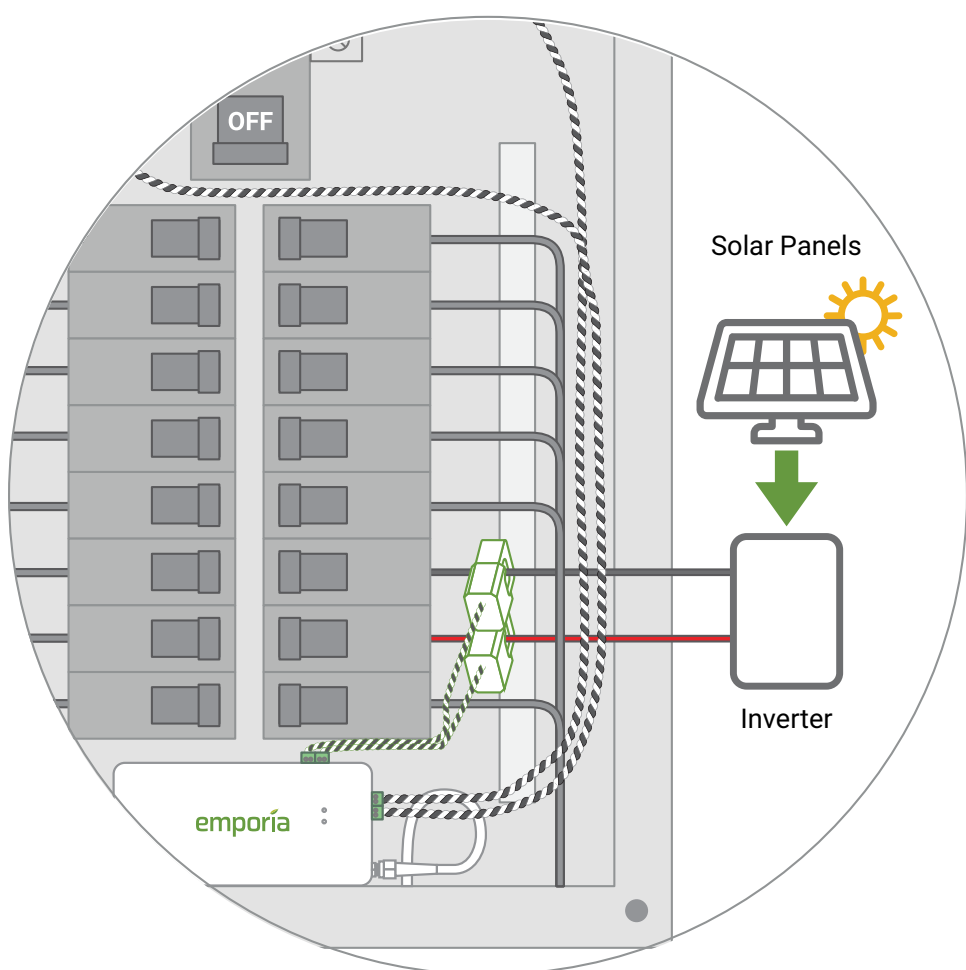

Need help?

emporiaenergy.com/support
support@emporiaenergy.com
1-844-EMPORIA (367-6742)

Step 10: Take a photo of your system

Before replacing your panel cover, take photos of the installation in case you need to contact support.

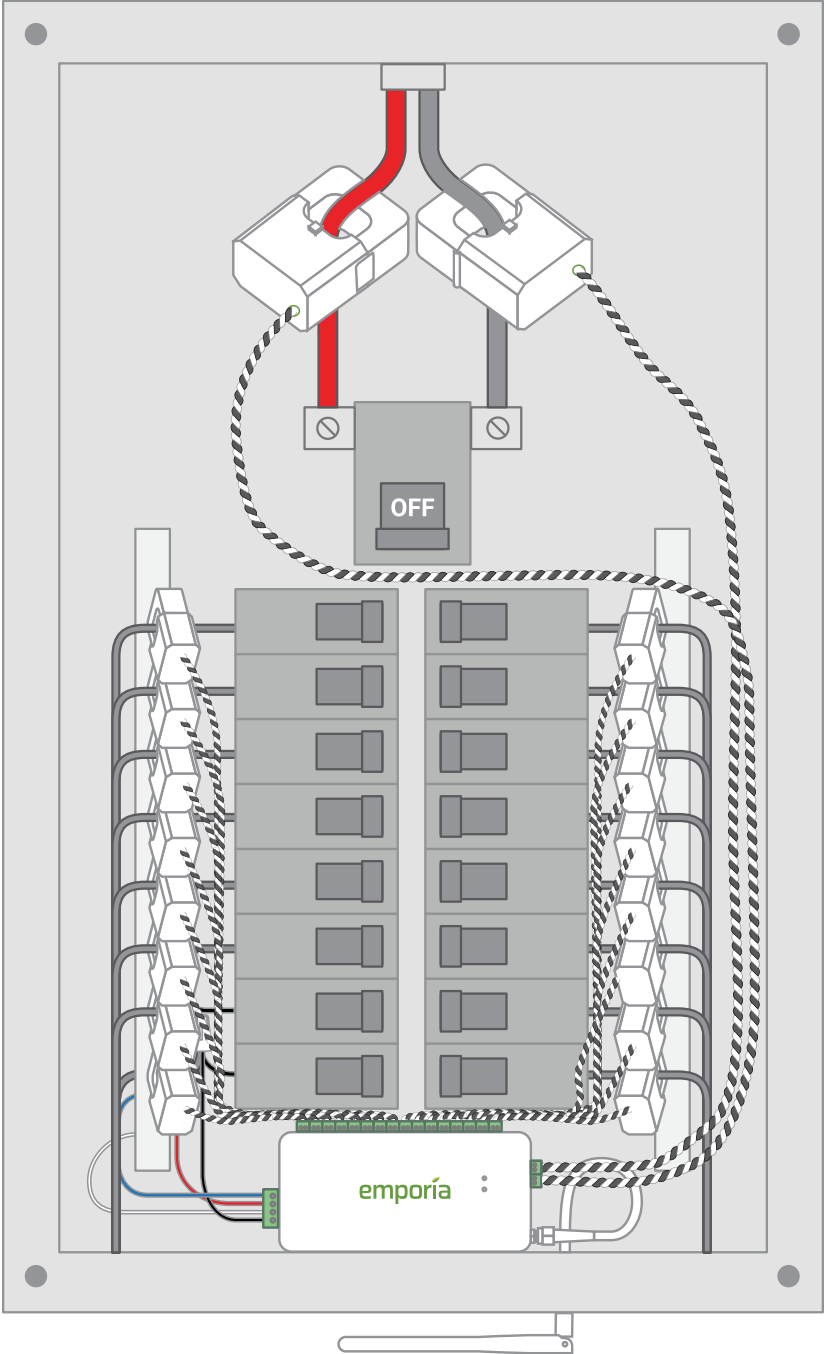

Need help?

emporiaeenergy.com/support
support@emporiaeenergy.com
1-844-EMPORIA (367-6742)

Step 11: Replace the cover and turn on all breakers

Secure the cover to the box with any screws you removed in Step 2. Next, return any breakers to the on position that you moved to the off position during installation to restore power to the circuits in the home. Then, close the panel. Once the panel cover is replaced, the antenna connector and screw terminal ports on the Vue will not be accessible.

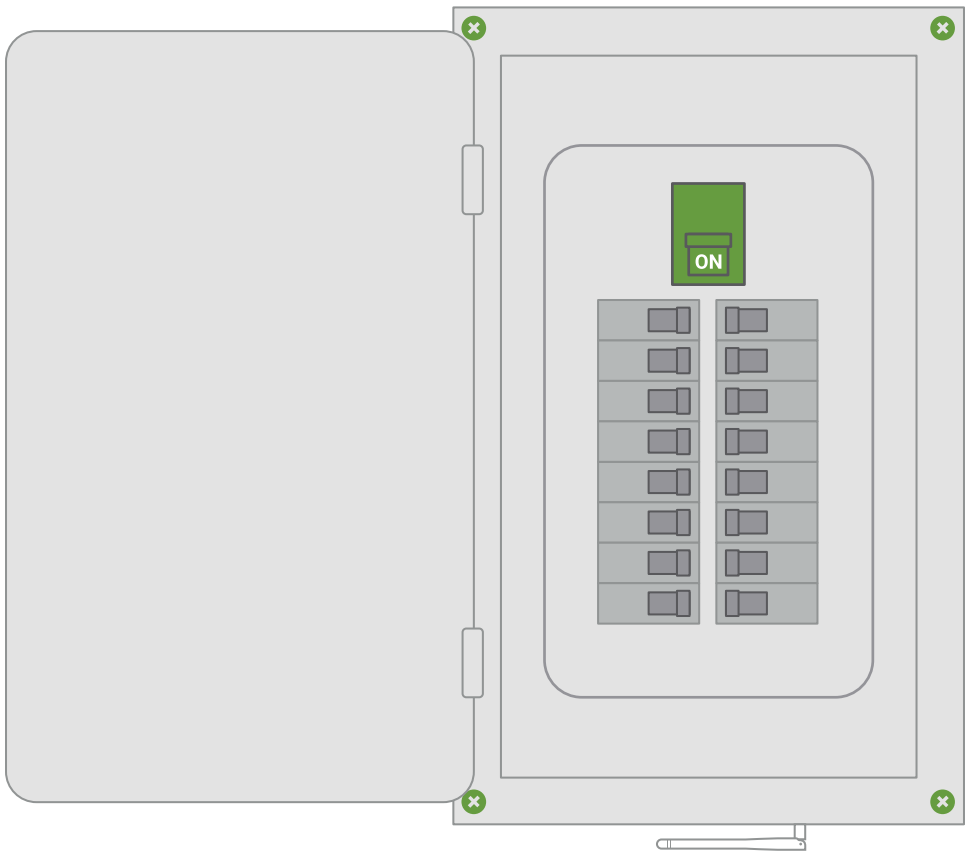

Need help?

emporiaenergy.com/support
support@emporiaenergy.com
1-844-EMPORIA (367-6742)

Step 11: Complete setup

Return to the Emporia app to continue the setup process that you began in Step 1 by **scanning the QR code on the Vue or Getting Started Guide** to connect the Vue to the internet via Wi-Fi or wired LAN connection.

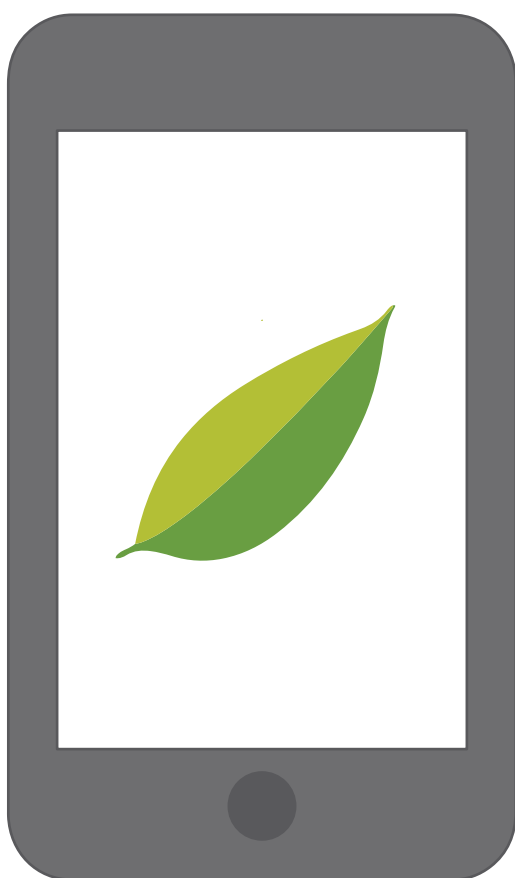

Need help?

emporiaenergy.com/support
support@emporiaenergy.com
1-844-EMPORIA (367-6742)

Troubleshooting Tips

Here are some of our most frequent troubleshooting tips. For more help, check out the Emporia Help Center online at help.emporiaenergy.com.

The Emporia app is not finding the Vue after I've installed it.

Ensure the Vue has power:

- Check for a flashing Wi-Fi light.
- Listen for a startup tone.
- Check the wire harness is secure and wired properly.
- Check that the main breaker is turned on.
- Check that the breaker powering the Vue is turned on.

Ensure your phone can connect to the Vue.

- Check your phone's Bluetooth is on.
- If you're using an Android, turn on Location Services for your phone to properly scan for Bluetooth devices.
- If you're using an iPhone, make sure Bluetooth is allowed in the **Settings > Emporia Energy app > Bluetooth allowed**

Ensure the Vue's Wi-Fi antenna is installed properly.

- Check the antenna is properly screwed into the energy monitor
- Ensure the antenna is outside of the electric panel. It's ok if it is inside a wall, just ensure it's not inside the metal box.

Ensure the Vue's wired LAN connection is installed properly

- Check that the ethernet cable is securely connected to the Vue's LAN port
- Check that the ethernet cable is securely connected to a' router, switch, or modem

Ensure the network does not have a firewall preventing new devices from accessing the internet

Try power cycling the breaker to which the Vue is connected.

Try restarting the Emporia App.

Try restarting your phone.

Troubleshooting Tips (continued)

The Emporia Energy app isn't getting real-time data from the Vue.

- Ensure all current transformers are securely fastened around their respective cables in the electric panel.
- Check the screw terminal plugs are securely plugged into the ports of the energy monitor.
- Check that the CT wires are securely connected to the screw terminals and that the screws are tight.

The Emporia app isn't showing solar net metering or grid measurements from the Vue.



- Ensure the Main CTs are clamped on the mains between the meter and incoming leads from the solar inverter.
- Ensure all CTs are oriented as per the instructions. CTs are directional.
- Check that the appropriate wiring harness wires are attached to adjacent breakers on
- different phases
- When configuring the Vue with the App, make sure that you temporarily turn the
- solar off so it is not supplying power to the system. Try running the configuration
- at night.
- When configuring the Vue with the App, make sure that there is a discernible load
- on the system. Try turning on an oven, A/C, or dryer.

Need help?

emporiaenergy.com/support
support@emporiaenergy.com
1-844-EMPORIA (367-6742)

Vue LED Lights

The Vue has two LED lights on the front of the energy monitor, that can help troubleshoot the status of the internet connection and whether or not the monitor has power.

 Wi-Fi (and indication of power)	
1 blink every 3 seconds	Not connected to router.
2 blinks every 3 seconds	Connected to router. Attempting Internet connection.
Solid green	Connected to Internet.
 Wired LAN	
Off	Not connected to router.
2 blinks every 3 seconds	Connected to router. Attempting Internet connection.
Solid Blue	Connected to Internet.

Need help?

emporiaenergy.com/support
support@emporiaenergy.com
1-844-EMPORIA (367-6742)

Technical Details

Energy Monitor (EMV3A)

- **Supported system configurations:**
 - Single phase, 2-wire systems (Up to 240V)
 - Single-split phase, 3-wire systems (Up to 240V/480V LN/LL)
 - 3-phase, 4-wire Wye systems with earthed (TN or TT) neutral (no-Delta)(Up to 240V/415V LN/LL)
- **Fuse:** 250VAC/4A (Slow Blow, TH)
 - Maximum voltage sense range: 264VAC L-N per channel
- **Power usage:** < 3 Watts
- **Wi-Fi:** 2.4 GHz IEEE 802.11b/g/n
- **Ethernet:** 10/100Base-T, IEEE 802.3
- **Operating conditions:** -40° to 122° F (-40° to 50° C) | 0 to 80% RH Up to 3,000 meters above sea level | Indoor | Dry location Pollution Degree 2

Terminals:

- **Ethernet:** Cat5e, RJ45, 600V insulation required
- **WiFi:** SMA coaxial cable, 50Ω impedance, 600V insulation required
- **Voltage Terminals:**
 - ~100-240VAC line-to-neutral, 50/60Hz, 41mA, Overvoltage / Measurement CAT III
 - Field terminal torque value: 5Lb-In/0.56Nm
 - 14AWG, UL1015, 600V, 105C copper-only wiring
- **Main Current Transformer Terminals:**
 - 3.3V, 1mA, Measurement CAT IV
 - Field terminal torque value: 5Lb-In/0.56Nm
 - 22AWG, UL1015, 600V, 105C copper-only wiring
- **Branch Current Transformer Terminals:**
 - 3.3V, 1mA, Measurement CAT III
 - Field terminal torque value: 3Lb-In/0.2Nm
 - 22AWG, UL1015, 600V, 105C copper-only wiring

Main Current Transformers (EMV3CT2-A)

- **Max primary current:** 200A
- **Max voltage:** 250V (Primary) / 333mV (Secondary)
- **Burden resistor:** 5ohm, 1%, 1/4W
- **Cable length:** 1m
- **Inside diameter:** 22 mm
- **Accuracy:** ±2% (above 4° F / -20° C)
 - Operating conditions: -40° to 122° F (-40° to 50° C) | 0 to 80% RH Up to 3,000 meters above sea level | Indoor | Dry location Pollution Degree 2

Branch Current Transformers (EMV3CT5-A)

- **Max primary current:** 50A
- **Max voltage:** 250V (Primary) / 333mV (Secondary)
- **Burden resistor:** 20ohm, 1%, 1/4W
- **Cable length:** 1m
- **Inside diameter:** 10 mm
- **Accuracy:** ±2% (above 4° F / -20° C)
 - Operating conditions: -40° to 122° F (-40° to 50° C) | 0 to 80% RH Up to 3,000 meters above sea level | Indoor | Dry location Pollution Degree 2



Measurement categories are defined by the CE and UL safety standard IEC 61010-1 and are used to indicate the ability of an instrument (like the Vue Energy Monitor) to withstand voltage spikes without posing a shock hazard to the operator. An instrument should only be used at or below its rated measurement category and voltage. For example, the Vue Energy Monitor is CAT III rated and can be used to monitor **CAT I**, **CAT II**, and **CAT III** circuits.

CAT III: This category is for measurements performed on equipment permanently installed in the building. Examples are measurements on motor control centers, circuit-breaker panels, junction boxes, switches, lighting fixtures, and wiring, including cables, bus-bars, and equipment for industrial use and some other equipment, for example, stationary motors with permanent connections to the electrical distribution system.

There are situations where the Vue Energy Monitor needs to monitor the main service entrance, which is classified as CAT IV. In this situation, the Vue voltage inputs (green screw terminal block) must be connected in a breaker panel or panel board, downstream of a the main disconnect, breaker, or fuses. The line voltages at this location will be essentially identical to the voltages measured at the main disconnect, so the Vue's measurements will be accurate.



IC: 28084-EMV3A

This device complies with Industry Canada licence-exempt RSS-247 standard. Operation is subject to the following two conditions: (1) this device may not cause interference, and (2) this device must accept any interference, including interference that may cause undesired operation of the device.

Le présent appareil est conforme aux CNR d'Industrie Canada applicables aux appareils radio exempts de licence. L'exploitation est autorisée aux deux conditions suivantes : (1) l'appareil ne doit pas produire de brouillage, et (2) l'utilisateur de l'appareil doit accepter tout brouillage radioélectrique subi, même si le brouillage est susceptible d'en compromettre le fonctionnement.

Need help?

emporiaenergy.com/support
support@emporiaenergy.com
1-844-EMPORIA (367-6742)



FCC ID:
2AS6P-EMV3A
Model: EMV3A

Federal Communication Commission Interference Statement

This equipment has been tested and found to comply with the limits for a Class B digital device, pursuant to Part 15 of the FCC Rules. These limits are designed to provide reasonable protection against harmful interference in a residential installation.

This equipment generates, uses and can radiate radio frequency energy and, if not installed and used in accordance with the instructions, may cause harmful interference to radio communications. However, there is no guarantee that interference will not occur in a particular installation. If this equipment does cause harmful interference to radio or television reception, which can be determined by turning the equipment off and on, the user is encouraged to try to correct the interference by one of the following measures:

- Reorient or relocate the receiving antenna.
- Increase the separation between the equipment and receiver.
- Connect the equipment into an outlet on a circuit different from that to which the receiver is connected.
- Consult the dealer or an experienced radio/TV technician for help.

FCC Caution: To assure continued compliance, any changes or modifications not expressly approved by the party responsible for compliance could void the user's authority to operate this equipment. (Example - use only shielded interface cables when connecting to computer or peripheral devices).

This device complies with Part 15 of the FCC Rules. Operation is subject to the following two conditions:

(1) This device may not cause harmful interference, and (2) This device must accept any interference received, including interference that may cause undesired operation.

Caution: Any changes or modifications not expressly approved by Emporia void the user's authority to operate the equipment.

Designed by Emporia Corp in Littleton, Colorado, USA.

Manufactured by VVDN Technologies Pvt. Ltd.

Plot No: CP-07, Sector-8, IMT Manesar, Gurugram, Haryana - 122050.

Need help?

emporiaenergy.com/support
support@emporiaenergy.com
1-844-EMPORIA (367-6742)

Memos